



heripack
verpackungsmaschinen.

case erector **AF-4000**

The case erector AF 4000 automatically erects cases of corrugated board with bottom flaps edge to edge. The bottom flaps can be sealed either with adhesive tape or hotmelt, at a speed up to 25 cases / minute.





heripack
verpackungsmaschinen.

case erector AF-4000

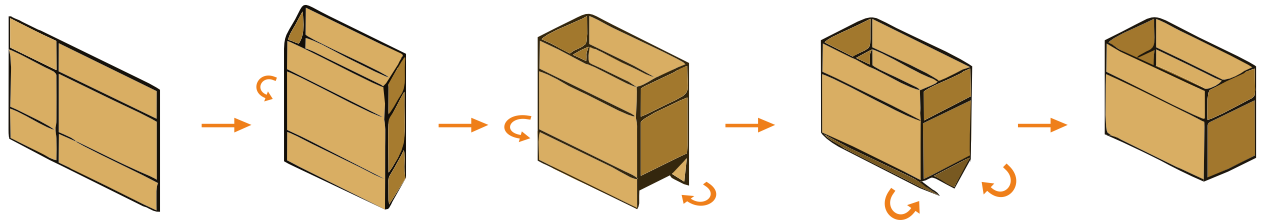

functional description

Pre-glued case blanks are positioned vertically in a horizontal magazine for being taken. The magazine can be refilled during production, without stopping the machine. A low installation of the magazine allows an easy and ergonomic refilling for the operators.

A traverse with vacuum powered suction cups picks up the single case blanks out of the magazine and erects them precisely rectangular. Then the inner bottom flaps are folded and the case is pushed right-angled into the side belt conveyors. These are spring-loaded in order to compensate manufacturing variations in case dimensions. During the belt transport the outer bottom flaps of the case are automatically folded and closed safely with adhesive tape or hotmelt.

your advantages

- » perfectly right-angled case closure
- » wide range of case dimensions
- » magazine can be refilled during production
- » no tools needed to change case dimension and consumption material
- » easy operation via 7" touch panel
- » barrier-free accessibility to the machine and good view insight
- » available in left or right version
- » consequent use of long-lasting and robust technology
- » 24 months warranty without limitation of number of pieces

options available

- » sealing with hotmelt
- » capacity increase, max. 30 cases per min
- » extension of magazine to 2,000 mm for longer refill intervals (about 250 cases)
- » processing of square cases
- » self-adhesive tape in widths 38 mm or 75 mm
- » machine frame on rolls
- » machine paint of any colour
- » machine frame and switch cabinet in stainless steel

Further options, functions, components and special sizes available on request!



heripack
verpackungsmaschinen.

case erector **AF-4000**

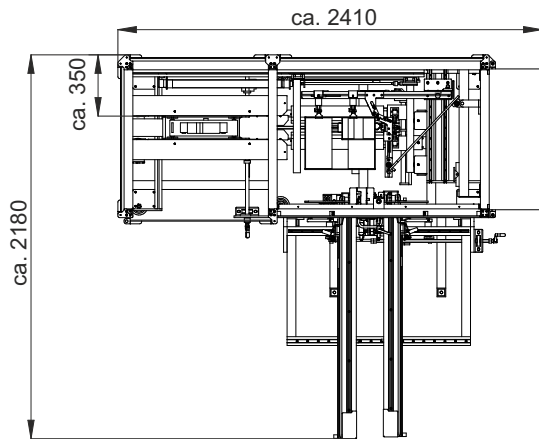

Magazin useful length ca. 1080

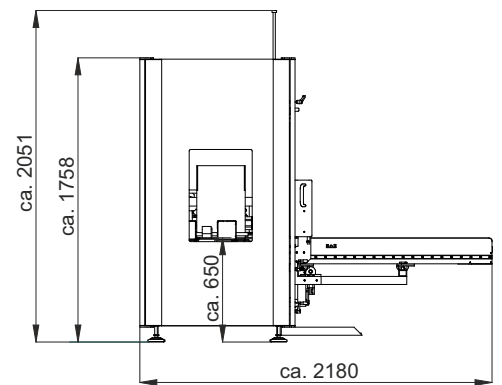
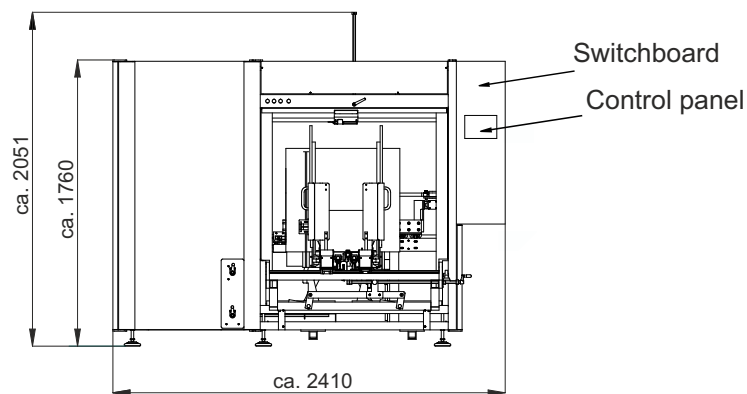
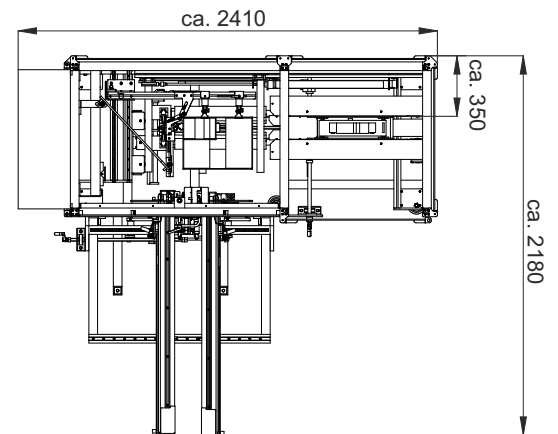

format range and capacity

outer dimensions	minimum	maximum
length (L)	190 mm	400 mm
width (W)	130 mm	300 mm
height (H)	125 mm	550 mm
height incl. flap (C)	190 mm	700 mm
capacity:	up to 25 cases / min, carton - depending	
format change:	approx. 3 minutes	

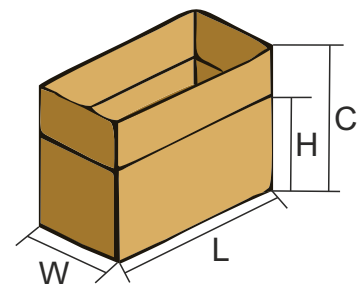

interfaces

exit height case bottom:	650 mm
height adjustment:	+/- 50 mm
compressed air supply:	6 bar, free of oil
connected voltage:	400 V AC, 50 Hz, 3 L-N-P-E
shipping weight:	about 870 kg
magazine capacity:	about 135 cases

carton criteria

carton type (Fefco) :	0200, 0201, 0204
corrugation type:	B, C, E - wave
no. of corrugation layers:	one, two or three-wave

Further carton types and formats available on request.



heripack
verpackungsmaschinen.

For over 40 years, Heripack Verpackungsmaschinen GmbH & Co. KG has been developing customised solutions for final packaging and palletising which are as individual as our customers themselves.

In developing our solution for you, it is important for us to remain flexible in our design concept. We listen carefully. We understand your aims. Which functions do you need? What special demands have to be met? This makes us part of your own unique production environment.

Even with complex tasks, we aim to keep things as simple as possible. To think and act from the point of view of the customer while retaining a high degree of intelligent pragmatism. As a flexible partner and specialist in the field of final packaging and palletising.

From our headquarters in Meschede, we supply semi-automatic high-performance packaging units as a first stage in automation, as well as fully automatic solutions for final packaging and palletising - everything from one single source. We use standard and special machines which our customers value for their quality, toughness and long life span.

Our best reference? Long-standing fully satisfied customers!

FINAL PACKAGING

box erectors • inserting • sealing • lidding and multipack machines • semi-automatic high-performance packaging stations

PALLETSTATION

layer • robotic • portal and column-type palletising units • Pallet-unloading units • pallet-securing • pallet-transport technology.

Heripack Verpackungsmaschinen GmbH & Co. KG

Linsemecke 6

59872 Meschede

phone: +49 291 9947-0 • fax: +49 291 9947-47

e-Mail: info@heripack.de • www.heripack.de